



PORSCHE



# The new Taycan

Soul, electrified.





The models featured in this publication are approved for road use in Germany. Some items of equipment are available as extra-cost options only. The availability of models and options may vary from market to market due to local restrictions and regulations. For information on standard and optional equipment, please consult your Porsche Centre. All information regarding construction, features, design, performance, dimensions, weight and running costs is correct to the best of our knowledge at the time of going to print (08/2019). Porsche reserves the right to alter specifications, equipment and delivery scopes without notice. Colours may differ from those illustrated. Errors and omissions excepted. More information in various languages is available at [www.porsche.com/BEV](http://www.porsche.com/BEV)



## Contents.

- 6 **Soul, electrified.**
- 16 **The Taycan**
- 20 Models
- 22 Design
- 26 Cockpit
- 28 Performance
- 32 Chassis
- 34 Assistance systems
- 36 **Charging**
- 40 **Porsche Connect**
- 42 **Personalisation**
- 46 **Technical data**



Discover the soul of the Taycan using the 'Porsche AR Visualizer' app. Wherever this symbol appears, you can unlock exciting digital content by activating the 'Scan image' function.





What makes an electric sports car the first all-electric Porsche?





A crest that lends  
metal a soul.



# A battery that stores goosebumps.

The Taycan carries a legacy that is reflected by performance. The latest drive technology ensures that its performance can be repeatedly reproduced: two permanent-magnet synchronous motors (PSMs) catapult the Taycan Turbo S with up to 560kW (761PS) overboost with Launch Control from 0–100km/h in 2.8 seconds. With a standing start performance of 1.2g, it accelerates faster than the force of gravity for the first few metres – making it faster than a skydiver in free fall.

For CO<sub>2</sub> emissions, all-electric range, electricity consumption and efficiency class, please refer to page 49 onwards.







# A cable with the power to fuel dreams.

The Porsche soul stands for performance. In every respect. As demonstrated by the Taycan, even when charging: its 800-volt architecture produces charge power of up to 270kW. In five minutes, the vehicle can be charged to enable a range of up to 100km (WLTP) under optimum conditions<sup>1)</sup> and is always ready for what its driver is thinking about the whole day: driving.

1) Optimum conditions: CCS fast-charging pedestal with >270kW, >850V, battery temperature 30°C to 35°C and initial charge status 5%.

For CO<sub>2</sub> emissions, all-electric range, electricity consumption and efficiency class, please refer to page 49 onwards.



A wide-angle, low-perspective shot of the interior of a Porsche Taycan. The view is from the driver's side, looking towards the front passenger side. The dashboard is a wide, dark, curved panel with a large digital display in the center. To the left is the steering wheel with the Porsche crest. The center console has a gear selector and handbrake. The passenger side has a large, curved panel with a digital display and various controls. The car is parked in a city street, with a sidewalk and a building visible through the windshield. The lighting is bright, suggesting daytime.

# A display that portrays emotions.

The Porsche Advanced Cockpit in the Taycan is characterised by pioneering technologies and offers up to four displays. The fully digital curved display is the driver's main focus. But what really distinguishes the Taycan is the feeling behind the wheel: the familiarity of a Porsche coupled with the irresistible beating of your heart.





The Taycan.

Its heart: electric.  
Its soul: Porsche.



The Taycan is ready for the future, thanks to its innovative total concept. It is characterised by the features that have always been decisive for any Porsche: pure emotion and maximum driving pleasure.

As you approach the Taycan in your garage, nothing stands in the way of your personal driving experience. The vehicle is fully charged, already knows your destination – transferred in advance via the Porsche Connect app – has planned the appropriate route and is pre-air conditioned ready for you to climb in.

You are instantly greeted by the familiar Porsche feeling – coupled with the latest technologies. The Porsche Advanced Cockpit boasts a fully digital 16.8-inch curved display, integrated 8.4-inch centre console control panel and 10.9-inch central display. Here, under 'Notifications', you'll find constantly updated information that is relevant to you. If you prefer to focus all your senses entirely on the road ahead, simply switch to the minimised view and only driving-relevant content will be displayed, such as speed and driving mode. As pure as the sports car experience behind it.

Then you put your foot on the pedal – and the Porsche soul of the Taycan is revealed: two permanent magnet synchronous motors producing up to 460kW (625PS) in the Taycan Turbo S unleash their full power from the start and allow acceleration that can be repeatedly reproduced. The low centre of gravity ensures exceptional cornering that instantly sets your pulse racing – just as you would expect of a Porsche.

As well as design and performance, the focus is also on comfort and range. If required, the car can plan your route, minimising the time taken and making long-distance journeys more comfortable. Fast-charging options make stops short – using the 800-volt architecture, when travelling, you can charge your car to achieve a range of up to 100km in five minutes (WLTP) under optimum conditions<sup>1)</sup>.

The intelligent Porsche Recuperation Management (PRM) is self-regulating or can be actively set by the driver – depending on the situation. Thanks to extremely efficient recuperation, valuable miles are also recovered while driving. For both sporty and efficient performance – as is typical of Porsche.

So nothing stands in the way of your next spin.

<sup>1)</sup> Optimum conditions: CCS fast-charging pedestal with >270kW, >850V, battery temperature 30°C to 35°C and initial charge status 5%.

For CO<sub>2</sub> emissions, all-electric range, electricity consumption and efficiency class, please refer to page 49 onwards.



A day in the Taycan.





# Models.

For CO<sub>2</sub> emissions, all-electric range, electricity consumption and efficiency class, please refer to page 49 onwards.

## Taycan Turbo S

- Up to 460kW (625PS) power output
- Up to 560kW (761PS) overboost with Launch Control
- 1,050Nm maximum torque with Launch Control
- 0 to 100km/h in 2.8 seconds with Launch Control
- Top speed of 260km/h
- Performance Battery Plus

## Taycan Turbo

- Up to 460kW (625PS) power output
- Up to 500kW (680PS) overboost with Launch Control
- 850Nm maximum torque with Launch Control
- 0 to 100km/h in 3.2 seconds with Launch Control
- Top speed of 260km/h
- Performance Battery Plus

Visit [www.porsche.com/taycan-highlights](http://www.porsche.com/taycan-highlights) to watch the Taycan launch film.



Puristic, expressive, timeless. Three attributes that describe every Porsche – and especially this one, which takes our DNA into a new automotive era.

The all-electric drive structure of the Taycan provides additional space that we have consistently exploited. The compact size of the electric drive allows an extremely flat bonnet design, resulting in the flat bonnet and pronounced wings that are typical of Porsche.

Lateral air intakes ahead of the front wheels – so-called **aircurtains** – also improve the aerodynamics, by guiding incoming air over the wheels like a curtain, thereby reducing turbulence. Directly above these is the highlight of the front: **four-point LED headlights** with matrix beam that combine all the light functions in a single component and appear to be floating.

The silhouette is characterised by a dynamic, flat flyline. Flush, **automatically extending door handles** open the vehicle interior with its deep, sporty seating position.

There are two roof options: the contoured variant made of lightweight aluminium with an indentation in the middle creates a shape that is known to us

from motorsport. Alternatively, a **panoramic fixed glass roof** provides an open, airy feeling.

The rear design features a seamless light strip made of glass, as well as the **'Porsche' logo in glass look**. Above these are the **Porsche Active Aerodynamics (PAA)** in the form of a three-stage rear spoiler system.

The cabin tapers backwards and the rear wings are extremely pronounced, as is typical of Porsche. And because there is no exhaust system, the Taycan does not need any tailpipes: leaving more room for a seamless rear diffuser with a sporty, slatted design. A car that reflects the future – and yet instantly reveals the Porsche soul.



## Exterior design.

Visit [www.porsche.com/taycan-design](http://www.porsche.com/taycan-design) to watch the design film.





## Interior design.

From the outside, it is instantly clear that this car is a Porsche. And in the interior, you can also sense distinctive Porsche genes in the new Taycan. The interior architecture is sporty, minimalist and clear; the wing extending from the centre console is particularly eye-catching and appears to be floating.

The ascending centre console underlines the deep, sporty position of the driver's seat. This takes the form of a 14 or optionally 18-way adjustable seat<sup>1)</sup> with narrow headrests. Recesses in the design of the battery integrated into the underbody also ensure an adequate level of comfort for rear passengers.

Behind the wheel, you feel that the Taycan has been tailor-made for you. While your front and rear passengers enjoy an equally comfortable, sporty ride on lightweight seats with solid lateral support. On request, your Taycan can also be fitted with a 4+1 seating configuration.

If the standard **multifunction sports steering wheel** is not sporty enough, you can maximise the motor-sport feel with the optional **multifunction GT sports steering wheel**<sup>2)</sup>: it features a mode switch, as well as a top centre marking.

For the interior, choose between **smooth-finish leather**, naturally treated **Olea club leather** and a **leather-free interior** in various colours. We also offer décor in aluminium, carbon or paldao wood. Accent packages enable selected interior details to be personalised, giving your vehicle an individual signature. On request, the Taycan also comes with **ambient lighting** that illuminates the interior.

The innovative **Advanced Climate Control** air conditioning (**dual or four-zone**) may not be visible, but is certainly noticeable: slat-free air outlets enable precise airflow and distribution.

As well as the 81-litre luggage compartment at the front for smaller items, the rear boot also provides 366 litres of storage space that can be flexibly expanded, thanks to the individually folding rear seat backrests.

The Porsche feeling in every seat – for all your senses, as soon as you climb in.

<sup>1)</sup> Standard on the Taycan Turbo S.

<sup>2)</sup> In conjunction with the Sport Chrono Package; standard on the Taycan Turbo S.





Touchscreen control panel for lighting functions

16.8-inch curved display

Touchscreen control panel for chassis functions

10.9-inch central display

10.9-inch front passenger display

Multifunction GT sports steering wheel including recuperation button

Advanced Climate Control (dual or four-zone)

Centre console with Direct Touch Control

Mode switch

# Cockpit.

We call the Taycan cockpit 'Advanced'. Because it has many pioneering features. It uses technology to increase its simplicity – while providing inspiration.

Mechanical buttons have been almost entirely replaced by digital ones. Making the interior look extremely tidy. The same principle of tidiness also applies to the displays, of which there are up to four – intuitive, distraction-free and easy to use. As you would expect of a Porsche. Simply climb in, select the D setting and drive off. If you prefer to start your Taycan manually, the ignition switch is on the left – because here too, we are remaining true to our roots.

The arrangement is also driver-focused, as is typical of Porsche: the instrument cluster is the centre of attention, consisting of a **16.8-inch curved display** and surrounded by control panels with Direct Touch Control for selecting lighting and chassis functions. It is angled and concave – and thus one of the first exposed curved displays to be installed in a car. This instrument cluster houses three freely configurable round instruments: recognisably Porsche, but in virtual form.

Your central control unit for audio, navigation and communication: redesigned **Porsche Communication Management (PCM)** including online navigation. The PCM display on the **10.9-inch central display** on the dashboard can be individually configured, allowing direct access to the most important functions.

Another digital element is located in the centre console, namely the **8.4-inch centre console control panel**. This provides access to navigation, media, telephone, settings and Apple CarPlay via a menu bar which can be disabled. The luggage compartment and charging flaps can also be opened and closed from here. The charging display and battery charge status can also be viewed.

In addition, the Taycan comes with an optional **front passenger display**, allowing access to navigation and infotainment functions, among other things. And, especially for passengers in the back seats, an optional **5.9-inch touchscreen display is available in the rear**, which can be used to operate comfort features, such as temperature, ventilation and seat heating.





1 Detailed view: 800-volt Performance Battery Plus with cell modules

The key to designing an outstanding drivetrain was the systematic continuation of the purpose-design approach: no compromises with the perfect interaction of drive components.

Two **Permanent Magnet Synchronous Motors** are therefore installed in the Taycan Turbo and Taycan Turbo S – one on each axle – and the performance battery is integrated deep into the underbody. The effect: superior driving dynamics and all-wheel drive that can be optimally adjusted to the fluctuation between efficiency and dynamics in the various driving modes.

The concept of the permanent magnet synchronous motor provides high power density, high continuous output and high efficiency in a compact design. A newly developed, automatically switching **two-speed transmission** on the rear axle ensures noticeably improved dynamics.

The interaction of the drive components produces impressive performance figures, both technically and emotionally: with up to **560kW (761PS) overboost** is activated with Launch Control, both machines accelerate the Taycan Turbo S from a standstill to 100km/h in 2.8 seconds. And this can be repeatedly reproduced: consecutive acceleration is possible, up to a top speed of 260km/h.

This is due to the performance battery, among other things, which is based on 800-volt technology instead of the usual 400 volts. The effect: improved charging and drive performance with smaller cable cross-sections, which has a positive impact on the overall weight.

Thus, the Taycan delivers high performance with a long range. This is E-Performance, as can only be found in a Porsche.

For CO<sub>2</sub> emissions, all-electric range, electricity consumption and efficiency class, please refer to page 49 onwards.

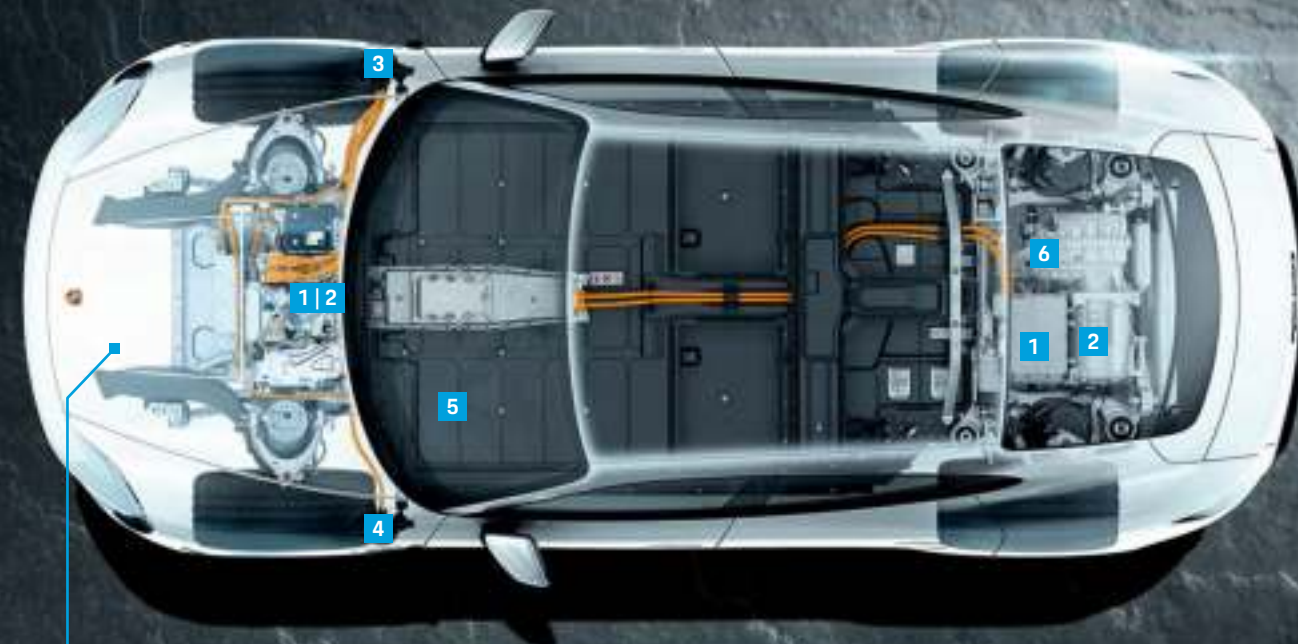

- 1 Power electronics
- 2 Permanent Magnet Synchronous Motors
- 3 Vehicle charge port (AC/DC)
- 4 Vehicle charge port (AC)
- 5 800-volt Performance Battery Plus
- 6 Two-speed transmission

# Performance.







With recuperation braking from

200 km/h

to 0

electrical energy can be recovered for an additional

4 km

range.

Performance.

1

The Taycan is fitted with the **Porsche Active Aerodynamics** system, consisting of an adaptive rear spoiler and adjustable cool air intakes, specifically for dynamic driving. Depending on the situation, the rear spoiler extends in three stages: at 90km/h, 160km/h and 200km/h, it demonstrates where an electric vehicle becomes a sports car and a sports car becomes a Porsche. The alloy wheels are also aerodynamically optimised. Depending on the model, standard 20-inch or even 21-inch wheels have a decisive impact on the design.

Thanks to the **Porsche Surface Coated Brake (PSCB)**, your Taycan decelerates with optimised responsiveness. Or choose the extremely light-weight **Porsche Ceramic Composite Brake (PCCB)** – standard on the Taycan Turbo S. Our high-performance brake has its origins in motorsport and enables short braking distances in even the toughest conditions.

The Taycan also has an efficient recuperation system for recovering braking energy. In this case, the electric motors act as generators if required, resulting in deceleration.

**Porsche Recuperation Management (PRM)** works innovatively and can regenerate up to 90% of braking energy. This means, during active braking, recuperation is enabled first and the mechanical brake is only engaged when stronger braking is required – intelligently controlled by a braking system that is capable of blending. With an outstanding recuperation output of up to 265kW, energy can be fed back into the battery in the Taycan. Or to be more precise: during sporty, everyday driving, for example, you will achieve up to a third of your range exclusively from recuperation. With recuperation braking from 200km/h to 0, electrical energy can be recovered for a range of up to 4km.

In addition to the brake pedal, we have also included the accelerator pedal in PRM, optimally combining sporty driving with efficiency. The three recuperation modes can be conveniently adjusted via a button on the steering wheel, for maximum control and personalisation.

Acoustically too, the Taycan provides an entirely new experience: it makes virtually no noise – all you can hear is the exterior sound that meets the legal requirements. For a unique acoustic accompaniment to dynamic driving, there is also the optional **Porsche Electric Sport Sound** – a system whose innovative character makes the vehicle's own drive sound appear even more emotional, both outside and inside. The ideal feedback for your right foot.

Experience Porsche Electric Sport Sound here: [www.porsche.com/taycan-sound](http://www.porsche.com/taycan-sound)

For CO<sub>2</sub> emissions, all-electric range, electricity consumption and efficiency class, please refer to page 49 onwards.



2

- 1 21-inch Mission E Design wheel painted in exterior colour **Porsche Exclusive Manufaktur**
- 2 Porsche Ceramic Composite Brake (PCCB): brake disc diameter 420mm front and 410mm rear



As with any Porsche, the chassis is also the supreme technical discipline in the Taycan. It uses all the Porsche chassis technologies to harmonise performance and comfort. The low centre of gravity due to the underbody battery is a distinct advantage when it comes to handling.

Intelligent chassis systems, most of which have already been proven in other Porsche models, help it to transfer its potential to the road:

**Adaptive air suspension** ensures a balance between comfort and performance, optimum aerodynamics and, last but not least, an improved drag coefficient: increased range with maximum performance.

**Porsche Active Suspension Management (PASM)** provides additional stability: an electronic damping control system that adjusts the damping force, based on current road conditions and your driving style. This prevents annoying body roll and improves comfort in all seats.

**Rear-axle steering** steers the rear wheels in the same or the opposite direction to the front wheels, depending on the speed. This has the virtual effect of shortening or extending the wheelbase – depending on the situation. For increased stability at high speed, improved lateral acceleration on country roads and a reduced turning circle in everyday situations.

The roll stabilisation of **Porsche Dynamic Chassis Control Sport (PDCC Sport)** also ensures sporty dynamics. This system, which is also used in other model ranges, almost entirely offsets lateral body inclination, thereby allowing the wheels to hold the road better. It also reduces lateral instability on uneven ground.

**Porsche Torque Vectoring Plus (PTV Plus)** enhances driving dynamics and stability. Depending on the steering angle and driving speed, accelerator pedal position, yaw rate and speed, it improves the steering behaviour and accuracy by precisely and agilely applying brake pressure to the left or right rear

wheel. At high speeds and when accelerating out of corners, the electronically controlled rear differential lock with fully variable torque distribution also acts to provide greater driving stability and traction.

To ensure that these systems interact perfectly, we have developed **Porsche 4D Chassis Control**: an integrated chassis control system that directs and synchronises the control units of the individual chassis components – for optimally balanced power electronics in every situation.

- 1 20-inch Taycan Turbo Aero wheel
- 2 20-inch Sport Aero wheel
- 3 21-inch Mission E Design wheel painted in exterior colour  
*Porsche Exclusive Manufaktur*
- 4 21-inch Taycan Exclusive Design wheel with carbon aeroblades  
*Porsche Exclusive Manufaktur*

Other alloy wheels are available in the Porsche Car Configurator.

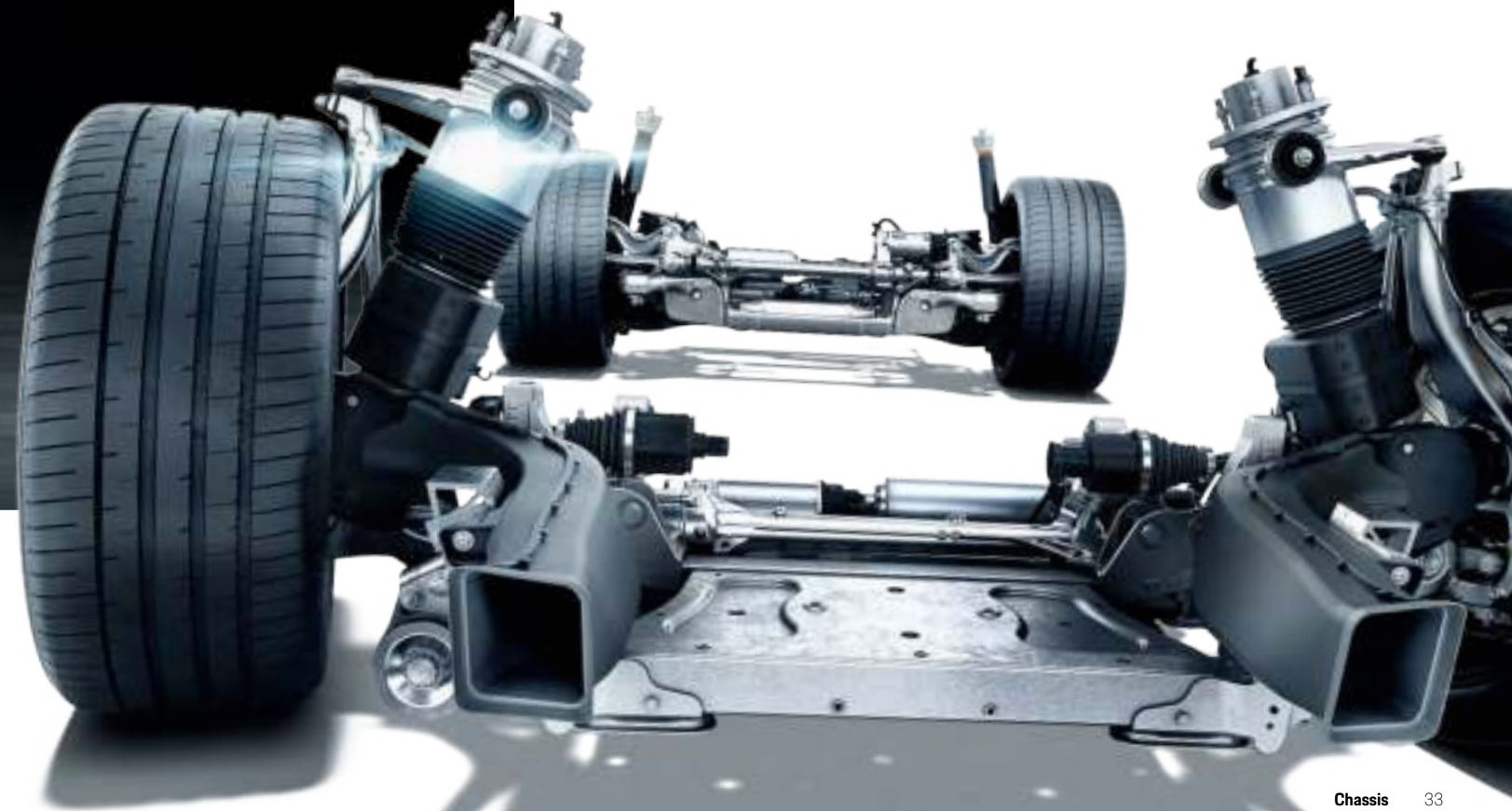

# Chassis.





Driving a sports car means being able to fully focus on the driving experience. While being confident that nothing will tarnish this.

**Adaptive cruise control (ACC)** automatically adjusts the distance from the vehicle ahead – for added comfort on country roads and motorways.

As part of intelligent **Porsche InnoDrive including adaptive cruise control**, the system increases the prediction horizon to up to 3km. With the aid of navigation data and information supplied by the radar and video sensors, it determines speed limits and topographical road features long before you reach them and modifies the speed and gearshift strategy to suit the selected driving mode. All according to Porsche standards. So you get more driving pleasure and efficiency from every metre.

**Active Lane Keeping**, which uses longitudinal and lateral control to help keep the Taycan in lane and regulate the distance from vehicles in front, is also an integral part of this system – as is **Traffic Jam Assist**, which keeps the vehicle in the middle of the lane on congested roads, for greater comfort on longer journeys.



**Lane Change Assist** indicates whether a vehicle is in your blind spot as you move to change lanes – extremely practical when driving on the motorway. And at night, **Night Vision Assist** uses an infrared camera to provide support – pedestrians and wildlife are displayed as thermal images and also highlighted in colour.

**Porsche Entry & Drive** allows you to leave your car key in your pocket, by recognising the encrypted access code stored on the key. The Taycan can be conveniently started using the electric power button to the left of the steering wheel or by simply selecting a gear.

**Surround View** ensures optimum care when parking and manoeuvring using one hand. Making every metre in the Taycan a driving experience – regardless of the speed.



Assistance systems.



In terms of charging time and range, the Taycan also demonstrates what makes a genuine Porsche. Because we believe that a sports car should be ready to set off at all times, we do our utmost to facilitate simple charging that is integrated into everyday life. Because the only thing you should think about is where to go next.

Our charging concept starts with the vehicle: the Performance Battery Plus with the latest lithium-ion technology is based on 800-volt architecture and, therefore, on a similar system to our endurance race car, the 919 Hybrid. Higher voltage means not only perceptibly more power and less weight, thanks to reduced cable size, but above all shorter charging times.

Because we not only think about the product, but also about the environment in which it is used, Porsche is involved in the development of a nationwide charging infrastructure: both with its own solutions and together with partners – along motorways, for example.

Today, several thousand rapid charging options are already available around the world. In conjunction

with the Porsche Charging Service, we will enable you to charge your vehicle at a constantly growing network of IONITY rapid charging stations in a number of European countries for a period of three years, without paying the basic fee.<sup>1)</sup>

**Porsche Turbo Charging** at selected Porsche Centres further expands the Porsche charging network. Here, you can charge your vehicle to achieve a range of up to 100km in five minutes (WLTP) under optimum conditions<sup>2)</sup>. Thanks to the on-board DC-charger with 50kW (optionally also with 150kW), you can also conveniently use public 400-volt charging stations.

Added to this are numerous alternating current (AC) charging options, at restaurants and hotels, for example, as well as in many city centres. You can conveniently use any charging point via the **Porsche Charging Service** (part of the Porsche Connect app).

All this makes your Taycan not only future-proof, but also suitable for everyday use.

1) Only via Porsche Charging Service at IONITY charging stations in Europe.  
2) Optimum conditions: CCS fast-charging pedestal with >270kW, >850V, battery temperature 30°C to 35°C and initial charge status 5%.

For CO<sub>2</sub> emissions, all-electric range, electricity consumption and efficiency class, please refer to page 49 onwards.



# Charging concept.



Charging in your own garage is the most obvious solution for many, because it can easily be integrated into their everyday routine. To do this, open the **electric charging flap**<sup>1)</sup> and connect the charging cable to your car.

Use the **Mobile Charger Plus**<sup>2)</sup>, connected to your mains supply, as standard to charge the vehicle. Or optionally charge using the intelligent Mobile Charger Connect with touchscreen. You can also conveniently attach the Mobile Charger Connect to your garage wall in the optionally available charging dock. The Porsche Connect app allows you to access information about the remaining charge time or charge level.

To enable you to quickly and easily charge your Taycan at home, we provide the **Home Energy Manager**: an intelligent control unit, installed in the power distribution box, which constantly communicates with your charger. It makes sure that your household electric appliances are supplied with sufficient energy while your car is being charged in the garage. For an initial assessment of your personal charging options, we recommend our **charging pre-check**. Your Porsche Centre will be happy to answer any questions about your results.

However, not only charging at home, but also charging on the road, should be undertaken intuitively and seamlessly. Which is why we already offer a network of several thousand charging facilities, together with partners such as **IONITY** and **Electrify America**.

In addition, our network of efficient **Porsche Turbo Chargers** is steadily growing. You can already charge your Taycan with up to 270kW at these 800-volt charging stations at many Porsche Centres. Added to this are thousands of public AC charging stations in city centres and at selected locations, such as luxury hotels or restaurants, for example, thanks to the **Porsche Destination Charging** network.

On the road, intelligent in-car systems assist with efficient range management. The **Charging Planner**<sup>3)</sup> plans your route, including charging stops. Furthermore, you can use the **Porsche Intelligent Range Manager** optionally available in selected countries to precisely adapt relevant systems on long journeys with active navigation, so as to minimise travel time, including charging stops.

Thanks to the **Porsche Charging Service**, charging at public pedestals is even easier: the **Porsche Connect app** allows you to locate charging pedestals in many countries and pay your bill. There is no need to register with the respective provider. Charging is conveniently administered and invoiced via your **Porsche ID account**.

Current charging facilities can be accessed at any time via Porsche Communication Management in your Taycan or online at [www.porsche.com/taycan-charging](http://www.porsche.com/taycan-charging)

- 1) Optionally available; standard on the Taycan Turbo S.  
2) Available from mid-2020 at the earliest.  
3) Not available in all countries.



Charging at home and on the road.



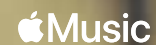

All your favorite music on the go.

Listen to 50 million songs ad-free effortlessly in your Taycan.



# Porsche Connect.

Connecting you to your Taycan and your Taycan to the world – **Porsche Connect**. The system extends the existing vehicle functions with intelligent digital services and apps. For the first time, you can also purchase individual functions after taking delivery of your car – depending on its configuration – via **Function on Demand (FoD)** in the Porsche Connect Store.

The basis for Porsche Connect is the **LTE communication module**. It ensures an optimised data connection in your Taycan.

In the Taycan, Porsche Connect has been expanded to include innovative services. Above all, **Voice Pilot**. Simply say "Hey Porsche" and your car will then respond to statements such as "I'm cold". Multimodal operation using both touch and voice commands is also possible: point to the map and say "Start navigation", for example.

When on the road, **Navigation Plus** continually retrieves real-time traffic information, so that you can avoid traffic jams and save time.

Relevant charging pedestals are synchronised for the **Charging Planner**<sup>1)</sup>, which allows you to plan routes to more distant destinations, including charging stops, and continuously updates the route.

You can keep an eye on this while driving using the **route monitor**. This provides a clear overview of the relevant real-time traffic, range and charging stop information – allowing you to fully focus on the pleasure of driving. With the help of **My Porsche**, you can also send the planned route to your car in advance or contact your Porsche Centre. You will receive your very own **Porsche ID** to use this service.

In addition, it supports **Apple CarPlay** which is a smarter, safer way to use your iPhone in your Taycan. CarPlay lets you get directions, send and receive messages, and more on the built-in PCM or using Siri voice control – to stay fully focused on the road.

Another Taycan highlight introduces the seamless integration of **Apple Music** directly in the PCM. Simply tap on Apple Music to stream over 50 million songs ad-free and curated playlists for any driving mood. Or create your own custom station on Apple Music from any radio song. New Taycan owners receive up to 6 months free of Apple Music.<sup>2)</sup>

To make your future workshop visits even more efficient, we will soon be offering optional **online software updates** for your Taycan. So your car always has the latest software version.



1) Not available in all countries.  
2) Depending on country. Apple Music requires a subscription.





21-inch Taycan Exclusive Design wheels with carbon aeroblades



Model designation on doors in black

- Light strip with 'PORSCHE' logo in Glacier Blue and 'Welcome' function
- Model designation painted in black (high-gloss)
- Carbon SportDesign package<sup>1)</sup>



LED main headlights with matrix beam in Glacier Blue, including Porsche Dynamic Light System Plus (PDLS Plus)

Exterior mirror upper trim in carbon

Accent package painted in exterior colour

21-inch Mission E Design wheels painted in exterior colour

Carbon SportDesign package<sup>1)</sup>

'PORSCHE' logo LED door projectors

SportDesign package

For CO<sub>2</sub> emissions, all-electric range, electricity consumption and efficiency class, please refer to page 49 onwards.

<sup>1)</sup> Available from mid-2020 at the earliest.

# Porsche Exclusive Manufaktur.

## The Taycan Turbo in Dolomite Silver Metallic and Mamba Green Metallic.





## Exterior colours.<sup>1)</sup>

### Solid colours.



White



Black

### Metallic colours.



Jet Black Metallic



Volcano Grey Metallic



Carrara White Metallic



Gentian Blue Metallic



Dolomite Silver Metallic



Mamba Green Metallic



Frozen Blue Metallic



Mahogany Metallic



Frozen Berry Metallic



Cherry Metallic



Coffee Beige Metallic

### Special colours.



Carmine Red



Neptune Blue



Crayon



Ice Grey Metallic

## Interior.<sup>1)</sup>

### Leather interior, smooth-finish leather.



Black



Slate Grey



Blackberry

### Leather interior in two-tone combination, smooth-finish leather.



Black and Bordeaux Red



Black and Chalk Beige



Black and Crayon



Blackberry and Slate Grey

### Leather-free interior.



Black



Graphite Blue



Slate Grey

### Leather-free interior in two-tone combination.



Black and Slate Grey

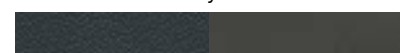

Graphite Blue and Slate Grey

### Leather interior, Olea club leather.



Truffle Brown



Basalt Black

### Leather interior Olea club leather in two-tone combination.



Basalt Black and Atacama Beige



Basalt Black and Meranti Brown

### Interior packages.



Matt carbon

*Porsche Exclusive Manufaktur*



Rhombus aluminium



Dark paldao open-pored

### Accent packages.



Black



Dark Silver



Neodymium



Painted in exterior colour

*Porsche Exclusive Manufaktur*

# Colours.

<sup>1)</sup> For all available colours and interiors, please visit [www.porsche.com/taycan-visualizer](http://www.porsche.com/taycan-visualizer) or your Porsche Centre.



## Porsche E-Performance drive

Model Battery variant	<b>Turbo S</b> Performance Battery Plus	<b>Turbo</b> Performance Battery Plus
Electric motor, front axle	Permanent Magnet Synchronous Motor	Permanent Magnet Synchronous Motor
Electric motor, rear axle	Permanent Magnet Synchronous Motor	Permanent Magnet Synchronous Motor
Power (kW/PS)	Up to 460/625	Up to 460/625
Overboost (kW/PS) with Launch Control	Up to 560/761	Up to 500/680
Maximum torque with Launch Control (Nm)	1,050	850

## Performance

Top speed (km/h)	260	260
Acceleration 0–100km/h (seconds) with Launch Control	2.8	3.2
Acceleration 0–200km/h (seconds) with Launch Control	9.8	10.6
Overtaking acceleration (80–120km/h) (seconds)	1.7	1.9

# Technical data.

## Charging

Model Battery variant	<b>Turbo S</b> Performance Battery Plus	<b>Turbo</b> Performance Battery Plus
Gross battery capacity (kWh)	93.4	93.4
Net battery capacity (kWh)	83.7	83.7
Charging time for AC (alternating current) with 11kW, from 0 to up to 100% (h)	9	9
Charging time for DC (direct current) with 50kW for up to 100km (WLTP) (min)	31	28
Charging time for DC (direct current) with 270kW for up to 100km (WLTP) under optimum conditions <sup>1)</sup> (min)	5.5	5
Charging time for DC (direct current) with 50kW, from 5% to up to 80% (min)	93	93
Charging time for DC (direct current) with 270kW, from 5% to up to 80% under optimum conditions <sup>1)</sup> (min)	22.5	22.5

<sup>1)</sup> Optimum conditions: CCS fast-charging pedestal with >270kW, >850V, battery temperature 30°C to 35°C and initial charge status 5%.

## Dimensions

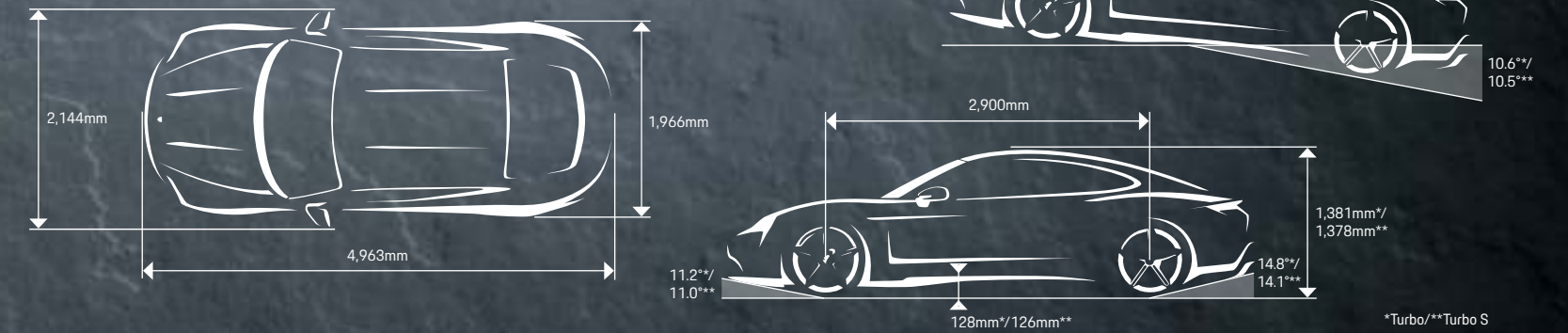

\*Turbo/\*\*Turbo S



## Chassis

Model Battery variant	<b>Turbo S</b> Performance Battery Plus	<b>Turbo</b> Performance Battery Plus
Turning circle diameter (m)	–	11.7
Turning circle diameter in conjunction with rear-axle steering (m)	11.2	11.2
Brakes	Ten-piston aluminium monobloc fixed brake calipers at the front, four-piston aluminium monobloc fixed brake calipers at the rear	Ten-piston aluminium monobloc fixed brake calipers at the front, four-piston aluminium monobloc fixed brake calipers at the rear
Brake discs, front axle diameter/thickness (mm)	420/40	415/40
Brake discs, rear axle diameter/thickness (mm)	410/32	365/28





## Weights

Unladen weight (DIN) (kg)	2,295	2,305
Unladen weight (EC) (kg) <sup>1)</sup>	2,370	2,380
Permissible total weight (kg)	2,870	2,880
Maximum permissible roof load with Porsche roof transport system (kg)	75	75

## Volume

Luggage compartment, rear (litres)	366	366
Luggage compartment, front (litres)	81	81

## Tyres



Tyre type	Size	Energy efficiency class/ rolling resistance	Wet grip class	External rolling noise <sup>2)</sup> (class)	External rolling noise (dB)
Summer tyres					
	245/45 R 20	B	A		71
	285/40 R 20	B	A		71
	265/35 ZR 21	C	A		72
	305/30 ZR 21	C	A		73

For logistical and technical reasons relating to the production process, we are unable to accept orders for a particular make of tyre.

## Range/fuel consumption/emissions<sup>3)</sup>

Model Battery variant	<b>Turbo S</b> Performance Battery Plus	<b>Turbo</b> Performance Battery Plus
Range (WLTP) (km)	388–412	381–450
Range (long-distance) (km) <sup>4)</sup>	340	370
Electricity consumption (combined) (kWh/100km), petrol equivalent Switzerland (l/100km) <sup>5)</sup>	26.9 3.0	26.0 2.9
CO <sub>2</sub> emissions (g/km) CO <sub>2</sub> emissions from electricity supply, Switzerland (g/km) <sup>5)</sup>	0 37	0 36
Efficiency class (Germany)	A+	A+
Efficiency class (Switzerland)	B	B

1) Weight is calculated in accordance with the relevant EC Directives and is valid for vehicles with standard specification only. Optional equipment increases this figure. The figure given includes 75kg for the driver.

2)  Quiet rolling noise,  Moderate rolling noise,  Loud rolling noise.

3) Data determined in accordance with the measurement method required by law. Since 1 September 2017 certain new cars have been type approved in accordance with the Worldwide Harmonised Light Vehicles Test Procedure (WLTP), a more realistic test procedure to measure fuel/electricity consumption and CO<sub>2</sub> emissions. As of 1 September 2018 the WLTP replaced the New European Driving Cycle (NEDC). Due to the more realistic test conditions, the fuel/electricity consumption and CO<sub>2</sub> emission values determined in accordance with the WLTP will, in many cases, be higher than those determined in accordance with the NEDC. This may lead to corresponding changes in vehicle taxation from 1 September 2018. You can find more information on the difference between WLTP and NEDC at [www.porsche.com/wltp](http://www.porsche.com/wltp) Currently, we are still obliged to provide the NEDC values, regardless of the type approval process used. The additional reporting of the WLTP values is voluntary until their obligatory use. As far as new cars (which are type approved in accordance with the WLTP) are concerned, the NEDC values will, therefore, be derived from the WLTP values during the transition period. To the extent that NEDC values are given as ranges, these do not relate to a single, individual car and do not constitute part of the offer. They are intended solely as a means of comparing different types of vehicle. Extra features and accessories (attachments, tyre formats, etc.) can change relevant vehicle parameters such as weight, rolling resistance and aerodynamics and, in addition to weather and traffic conditions, as well as individual handling, can affect the fuel/electricity consumption, CO<sub>2</sub> emissions and performance values of a car.

4) Guide value determined in accordance with a partial WLTP cycle (including allowing for auxiliary equipment such as air conditioning)

5) The average CO<sub>2</sub> emissions value of all new vehicles sold in Switzerland is 137g/km.



# Important information.

## I. Range

The ranges determined using the standard WLTP cycle enable comparison between manufacturers. They also include the measuring reach achieved through recuperation (energy recovery during braking). The additionally specified long-distance range provides a guide value for journeys over longer distances. This is based on a partial WLTP cycle that is characteristic of long-distance journeys, allowing for additional auxiliary equipment (e.g. air conditioning). Various factors, such as driving style, traffic situation, topography, speed, use of comfort/auxiliary equipment (e.g. air conditioning, Infotainment, etc.), outside temperature, number of passengers, payload and selected driving mode (e.g. Sport), can have a negative impact on the actual range.

## II. Battery

A lithium-ion battery is subject to physical and chemical ageing, as well as wear and tear. This reduces the battery capacity, depending on the usage pattern and environmental conditions, resulting in a reduction in range and an increase in charging times as the battery ages. Due to the effect of temperature on battery and charging performance, as well as battery life, please consider the following when parking, driving and charging your car:

- If possible, avoid permanent ambient temperatures of over 30°C, such as prolonged parking in direct sunlight.
- If you cannot avoid ambient temperatures of over 30°C when stationary, connect the vehicle to the mains supply after use and charge the high-voltage battery with AC (alternating current) to a maximum charge status of 85%.
- If the car is left stationary for more than two weeks, the ambient temperature should, if possible, be between 0°C and 20°C and the battery charge status maintained between 20% and 50% during this time.
- For the shortest possible charging time, a battery temperature of approx. 30°C to 35°C is ideal.
- If charging the car on a daily basis, the maximum charge status of the high-voltage battery should be set to approx. 80%.

## III. Charging

The specified charging outputs and times are dependent on various factors: in general, the charging output and time can vary due to physical and chemical limits, depending on factors such as the available output of the country-specific energy infrastructure, the customer's own domestic installation, the temperature, interior pre-conditioning and charging status, as well as the age of the battery. Charging times may therefore be significantly higher than those specified. To achieve the optimum value of the specified DC charging time (DC = direct current) for a charge status increase from 5 to 80%, a CCS (combined charging system) fast-charging pedestal with > 270kW and > 850V is required, as well as a battery temperature of 30°–35°C. The charging status when commencing charging must not exceed 5%. The determination of the specified charging time for a WLTP range of 100km is based on the same prerequisites. For physical and chemical reasons, the charging speed decreases as the battery approaches its full capacity. Therefore, it usually makes sense to use fast DC charging to charge the battery up to 80% or up to the required range. The predominant use of CCS fast-charging pedestals leads to a long-term increase in charging times. For regular fast DC charging, we recommend a maximum charging output of 50kW. When charging in a domestic environment, AC charging (AC = alternating current) is recommended. Using an (AC) industrial electrical outlet will result in improved efficiency and a much shorter charging time compared to using a household socket.

## IV. Drive power

In general, the available drive power in battery-operated electric cars depends on various factors, such as the duration of the required performance, as well as the battery voltage and temperature. The specified power is available for at least 10 seconds and the specified overboost with standard launch control for at least 2.5 seconds. Extremely sporty driving or charging at a fast-charging pedestal can result in an increase in battery temperature and, therefore, in temporarily reduced drive power. Due to the physical environment, the maximum power required to achieve the specified acceleration values can be repeatedly produced, but usually not consecutively.







© Dr. Ing. h.c. F. Porsche AG, 2019

All text, images and other information in this catalogue are subject to the copyright of Dr. Ing. h.c. F. Porsche AG.

Any reproduction, duplication or other use is prohibited without the prior written consent of Dr. Ing. h.c. F. Porsche AG.

Dr. Ing. h.c. F. Porsche AG supports the use of paper from sustainable forests. The paper for this sales brochure is certified in accordance with the strict regulations of the PEFC (Programme for the Endorsement of Forest Certification).

Porsche, the Porsche Crest, Taycan, PCCB, PCM, PSM and other marks are registered trademarks of Dr. Ing. h.c. F. Porsche AG.

Dr. Ing. h.c. F. Porsche AG  
Porscheplatz 1  
70435 Stuttgart  
Germany  
[www.porsche.com](http://www.porsche.com)

Effective from: 09/2019  
Printed in Germany  
WSLT1901000120 EN/WW